

TFV : for very narrow components packaged in plastic sticks

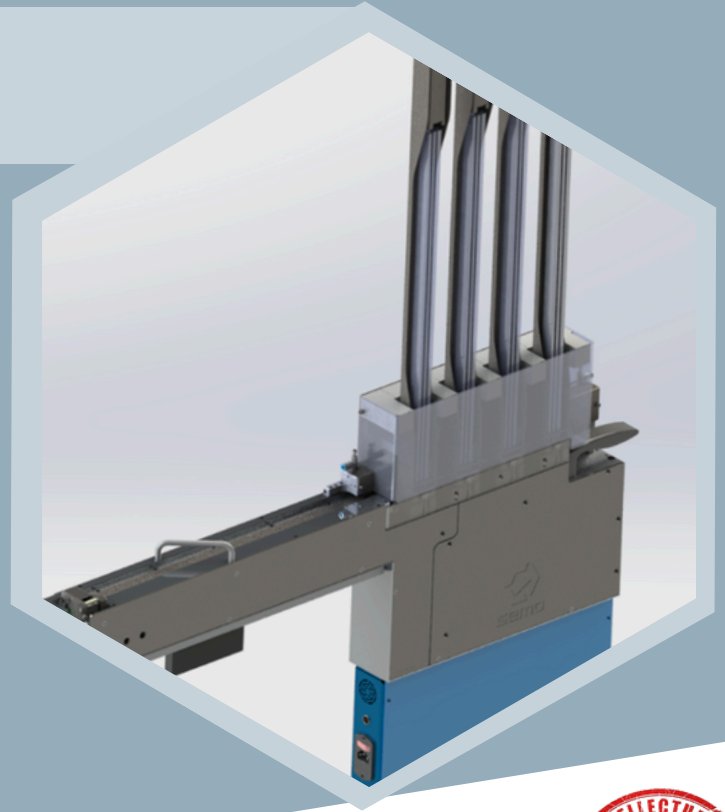
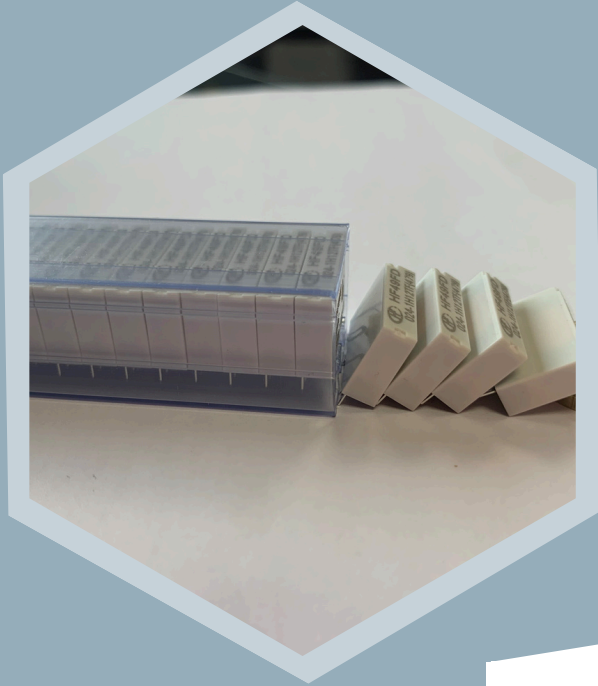

**Width :** 80 mm

**Length :** 1043 mm (533 out table)

**Weight :** 24 kg

**Power supply :** 110/220 Vac - 50/60 Hz

**Air supply :** 5 / 7 bar

## GENERAL CONCEPT



- ▶ Reliable and stable feeding of very narrow parts for the highest OEE
- ▶ Shortest stick feeder on the market
- ▶ Simple mechanical systems
- ▶ Loading of full sticks and unloading of empty sticks while feeding parts (no impact on production)

### DID YOU KNOW ?



What to do when your component is discontinued ?

**SEMO Feeders can be recycled**

We can reconfigure to new components, test, upgrade and provide the new full warranty: **a new life for your feeder and some savings for you**

# INTEGRATION FOR MULTIPLE MANUFACTURERS

- Possible integration with many pick-and-place machines
- SEMO feeders can communicate with pick-and-place machines or can function manually for tests and maintenance.

## CHARACTERISTICS

- ▶ **Automatic startup with cycle time** < 1.5s
- ▶ **Lengths of sticks** : 500 mm to 600 mm maximum
- ▶ **Number of sticks** : 4
- ▶ **Stick replenishment without stopping production**
- ▶ **Repeatability of positioning** : < 0.1 mm
- ▶ **SEMO Tube Feeder can be mounted on a changeover table every 80mm**
- ▶ **Optional communication for optimal synchronization with pick and place machine**
- ▶ **A mobile crutch supports the feeders weight once mounted on a placement machine**
- ▶ **Reconfigurable** if you need to convert your feeder to another component

## ACCESSORIES

### Trolley :

- ▶ To handle feeders
- ▶ Electrical/Pneumatic connections plate
- ▶ Storage box with four drawers
- ▶ Additional storage interface

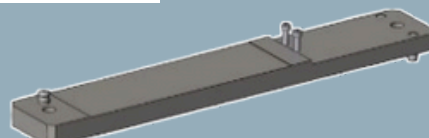

+33 5 61 85 55 77  
[semo@semo.fr](mailto:semo@semo.fr)  
10 rue Louis Breguet,  
31700 Cornebarrieu, FRANCE

